

2012

FORD CHASSIS FOR  
**SHUTTLE BUS**  
APPLICATIONS



**E-350/E-450 Super Duty Cutaway**  
**F-550 Super Duty Chassis Cab**  
**F-650 Medium Duty Chassis Cab**

# E-Series Super Duty Cutaway for 2012

**Ford E-Series Super Duty Cutaway** has long been the “chassis of choice” of shuttle bus customers and builders. Shuttle buses provide comfort, convenience, maneuverability, safety, versatility and value for the dollar—the same attributes that make E-Series the sales leader in this segment.

## Shuttle Bus Prep Package (47B)

This package, available on E-350 and E-450 Cutaways, is designed for shuttle bus manufacturers and includes the following:

- High Series Exterior Upgrade Package (18A) which includes Front Chrome Bumper, Chrome grille, Dual beam headlamps w/fixed lens
- Manual Pedestals, seats not included (21W)
- Power Windows and Locks Group – incl. one touch down driver window (903) N/A with RH door delete (60X)
- Frame pucks (isolators – included when spacers not ordered)
- Front Max GAWR on E-450
- Engine block heater
- Front license plate bracket (153)
- Exterior Mirror Delete (54F)
- Heavy Duty 157-Amp Alternator (63M) Incl. with 5.4L and 6.8L Gas engines.
  - Can upgrade to Extra Heavy Duty 225-Amp Alternator (63N) with either engine

## Deletes:

- Front headliner/Front dome lamp/Front vinyl floor covering
- Note - Front vinyl floor covering (162) may be added back

## TorqShift® Automatic Overdrive Transmission and Tow/Haul Mode

This tough, durable 5-speed automatic overdrive transmission features a high-mileage internal transmission filter and long service intervals. The selectable Tow/Haul Mode helps reduce gear hunting, improves power delivery and uses engine braking to help control vehicle speed when descending steep grades.

## Optional Traction Control

- Available on E-350 and E-450, the system uses ABS and engine torque to monitor vehicle speed and wheel slip. If wheel slip is detected, engine torque is automatically optimized to help maintain traction.

## New Optional Ford Work Solutions™

- Crew Chief™ – a telematics and diagnostics system powered by Telogis®, allows operators to efficiently manage and dispatch their vehicles, and keep detailed vehicle maintenance records. The system delivers real time vehicle location tracking to identify vehicle proximity to the required destination. Requires additional subscription service.

## Choice of Engine Power

Two responsive, dependable powerplants are available offering a wide range of performance characteristics:

- 5.4L Triton® V8 Gasoline (E85 Flex-Fuel capable)
- 6.8L Triton® V10 Gasoline
- CNG/LPG Gaseous Engine Prep Package (91G) available
- 50-State Emissions System (425) Standard



ITEM	E-350 SUPER DUTY CUTAWAY CHASSIS w/47B			E-450 SUPER DUTY CUTAWAY CHASSIS w/47B	
WHEELBASE (in.)	138	158	176	158	176
MAX. GVW RATINGS (lbs.)	10,050 (SRW) 11,500 (DRW)	10,050 (SRW) 12,500 (DRW)	12,500 (DRW)	14,050 (DRW w/5.4L Gas) 14,500 (DRW w/6.8L Gas)	14,500 (DRW w/6.8L Gas)
MAX. FRONT GAWR (lbs.)	5,000			5,000	
AXLE, FRONT (lbs.)	5,000 Twin-I-Beam IFS			5,000 Twin-I-Beam IFS	
AXLE, REAR (lbs.)	7,800 (SRW); 8,500 (DRW), Dana Full Floating			9,600, Dana Full Floating	
AXLE RATIO	4.10 (Std.); 4.10 LS (Opt.) 3.73 (Std. w/44Q); 3.73 LS (Opt. w/44Q)			4.56 (Std.); 4.56 LS (Opt.)	
BRAKES, SERVICE	Power, Self Adjusting Hydro-Boost Assist			Power, Self Adjusting, Hydro-Boost Assist	
BRAKE, PARKING	Four Wheel Disc with Four Wheel Anti-Lock			Four Wheel Disc with Four Wheel Anti-Lock	
ELECTRICAL - ALTERNATOR (GAS ENGINE)	Rear Axle Mounted Drum-In-Hat Type, Foot Operated 157-Amp Heavy Duty (Std.) 225-Amp (Opt.)			Rear Axle Mounted Drum-In-Hat Type, Foot Operated 157-Amp Heavy Duty (Std.) 225-Amp (Opt. w/6.8L)	
- BATTERY (GAS ENGINE)	12-Volt, 650-CCA/72-Amp Hr (Std.) Dual 78-Amp Hr HD (Opt.)			12-Volt, 650-CCA/72-Amp Hr (Std.) Dual 78-Amp Hr HD (Opt.)	
ENGINE/HP/TORQUE	5.4L Triton® V8 - Flex Fuel Capable (Std.) 255 HP @ 4,500 RPM/350 lb.-ft. Torque @ 2,500 RPM 6.8L Triton® V10 (Opt.) 305 HP @ 4,250 RPM/420 lb.-ft. Torque @ 3,250 RPM			5.4L Triton® V8 - Flex Fuel Capable (Std.) 255 HP @ 4,500 RPM/350 lb.-ft. Torque @ 2,500 RPM 6.8L Triton™ V10 (Opt.) 305 HP @ 4,250 RPM/420 lb.-ft. Torque @ 3,250 RPM	
FRAME	Single Channel 36,000 PSI 5.73 Cu. In. Section Modulus			Single Channel 36,000 PSI 6.4 Cu. In. Section Modulus	
FUEL TANK	40.0 Gallon (140L) Aft-of-Axle (Std.) 55.0 Gallon (208L) Aft-of-Axle (Opt. w/158" DRW only)			55.0 Gallon (208L) Aft-of-Axle (Std.) 40.0 Gallon (140L) Aft-of-Axle (Opt.)	
SHOCK ABSORBERS	1.38" HD Gas-Type, Front and Rear			1.38" HD Gas-Type, Front and Rear	
SPRINGS, FRONT COIL TYPE (lbs.)	4,200 Max. (SRW) 4,600 Max. (DRW)	5,000 Max.	5,000 Max.	5,000 Max.	
SPRINGS, REAR (lbs.)	7,310 (SRW); 8,500 (DRW) Multi-Leaf/Single Stage			9,600 Multi-Leaf/Single Stage	
STABILIZER BAR, FRONT (in.)	1.0 (SRW); 0.91 (DRW) diameter			0.91 diameter	
STABILIZER BAR, REAR (in.)	1.125 (DRW) diameter			1.125 diameter	
STEERING	HD Power			HD Power	
TIRES	(4) LT245/75R16E (SRW); (6) LT225/75R16E (DRW)			(6) LT225/75R16E (Std.)	
WHEELS, 8-HOLE DISC	(4) 16.0x7, Gray (Std.), White (Opt.) (SRW) (6) 16.0x6, White 4 Hand Hole (DRW) (4) 16.0x7 Forged Aluminum (Opt.) (SRW)			(6) 16.0x6, White 4 Hand Hole	
TRANSMISSION	4R75E 4-Speed automatic Overdrive (Opt. w/5.4L) 5-Speed, TorqShift® Automatic Overdrive; In-Tank Oil Cooler (Std.) Tow/Haul Mode (Std.) Auxiliary Transmission Oil Cooler (Std.)			5-Spd. TorqShift® Automatic Overdrive; In-Tank Oil Cooler (Std.) Tow/Haul Mode (Std.) Auxiliary Transmission Oil Cooler (Std.)	

SRW - Single Rear Wheel

DRW - Dual Rear Wheel

# Ford Has The Right Chassis To Fit Your Transportation Needs



## E-Series Super Duty Cutaway Chassis for 2012

PEP Code	Body Code	2012 Model			Engine Code	Transmission Code*	SRW/DRW	GVWR Code	GVWR (lbs.)
		Model	WB	Engine					
780A	E3F	E-350	138" WB	5.4L Gas	99L	44Q	SRW	20Q	9,600
780A	E3F	E-350	158" WB	5.4L Gas	99L	44Q	SRW	20Q	9,600
780A	E3F	E-350	138" WB	5.4L Gas	99L	44Q	DRW	20W	10,000
780A	E3F	E-350	158" WB	5.4L Gas	99L	44Q	DRW	20W	10,000
780A	E3F	E-350	176" WB	5.4L Gas	99L	44Q	DRW	20W	10,000
780A	E3F	E-350	138" WB	5.4L Gas	99L	44Q	DRW	20X	10,050
780A	E3F	E-350	158" WB	5.4L Gas	99L	44Q	DRW	20X	10,050
780A	E3F	E-350	176" WB	5.4L Gas	99L	44Q	DRW	20X	10,050
780A	E3F	E-350	138" WB	5.4L Gas	99L	44T	SRW	20B	9,900
780A	E3F	E-350	138" WB	6.8L Gas	99S	44T	SRW	20B	9,900
780A	E3F	E-350	138" WB	5.4L Gas	99L	44T	DRW	20W	10,000
780A	E3F	E-350	138" WB	6.8L Gas	99S	44T	DRW	20W	10,000
780A	E3F	E-350	158" WB	5.4L Gas	99L	44T	DRW	20W	10,000
780A	E3F	E-350	158" WB	6.8L Gas	99S	44T	DRW	20W	10,000
780A	E3F	E-350	176" WB	5.4L Gas	99L	44T	DRW	20W	10,000
780A	E3F	E-350	176" WB	6.8L Gas	99S	44T	DRW	20W	10,000
780A	E3F	E-350	138" WB	5.4L Gas	99L	44T	SRW	20X	10,050
780A	E3F	E-350	138" WB	6.8L Gas	99S	44T	SRW	20X	10,050
780A	E3F	E-350	158" WB	5.4L Gas	99L	44T	SRW	20X	10,050
780A	E3F	E-350	158" WB	6.8L Gas	99S	44T	SRW	20X	10,050
780A	E3F	E-350	138" WB	5.4L Gas	99L	44T	DRW	20Y	11,500
780A	E3F	E-350	138" WB	6.8L Gas	99S	44T	DRW	20Y	11,500
780A	E3F	E-350	158" WB	5.4L Gas	99L	44T	DRW	20Y	11,500
780A	E3F	E-350	158" WB	6.8L Gas	99S	44T	DRW	20Y	11,500
780A	E3F	E-350	158" WB	5.4L Gas	99L	44T	DRW	20C	12,500
780A	E3F	E-350	158" WB	6.8L Gas	99S	44T	DRW	20C	12,500
780A	E3F	E-350	176" WB	5.4L Gas	99L	44T	DRW	20C	12,500
780A	E3F	E-350	176" WB	6.8L Gas	99S	44T	DRW	20C	12,500
782A	E4F	E-450	158" WB	5.4L Gas	99L	44T	DRW	206	14,050
782A	E4F	E-450	176" WB	5.4L Gas	99L	44T	DRW	206	14,050
782A	E4F	E-450	158" WB	6.8L Gas	99S	44T	DRW	20F	14,500
782A	E4F	E-450	176" WB	6.8L Gas	99S	44T	DRW	20F	14,500

\* Transmissions: 4R75E 4-speed automatic overdrive (44Q), 5-speed automatic TorqShift® with Tow/Haul Mode (44T)

### E-Series Super Duty Cutaway

Widest Range of Available Gross Vehicle Weight Ratings (GVWR).

A wide variety including the highest GVWR in the segments as well as some under 10,000 lbs. GVWR offerings.



# F-550 Super Duty Chassis Cab for 2012

## Wheelbase Choices

F-550 Super Duty Regular Cab Chassis models are available in 4 wheelbase lengths and 4 CA dimensions.

## Choice of Powertrains

Two responsive and dependable powertrains are available.

- The tough and reliable 6.8L Triton® V10 Gasoline engine mated to the durable TorqShift® 5-speed automatic transmission with overdrive: The TorqShift automatic includes Tow/Haul Mode which helps reduce gear hunting, improves power delivery and uses engine braking to help control vehicle speed when descending hills. The 0.71 overdrive contributes to reduced engine noise and improved fuel efficiency when cruising.
- The 6.7L Power Stroke® V8 Turbo Diesel engine offers great performance and fuel economy. This Ford designed and built engine includes a four-valve per cylinder design, a robust head-to-block sealing/retaining system, and a new, cleaner, exhaust emissions control system. This system uses Diesel Emissions Fluid (DEF) to reduce emissions, resulting in the cleanest Super Duty® diesel engine ever! The engine is mated to the TorqShift® Heavy-Duty 6-Speed SelectShift Automatic™ transmission with overdrive which offers progressive range select for greater driver control of the transmission and Tow/Haul Mode which helps reduce gear hunting, improves power delivery and uses engine braking to help control vehicle speed when descending hills. On the 6.7L diesel, engine exhaust braking is seamlessly integrated into the Tow/Haul Mode.

## Selection of Gross Vehicle Weight Ratings (GVWRs) and Payload

Shuttle bus customers and builders can select GVWRs ranging from 17,500 lbs. to 19,500 lbs. and payloads ranging from 9,351 to 12,682 lbs. (Regular Cab).

## Optional Ford Work Solutions™

- Crew Chief™ - a telematics and diagnostic system, powered by Telogis®, requires additional subscription service.

## Airbag Delete Option for Front Entry Buses

In order to assist the builder with a front entry door, Ford offers a Frontal Passenger and Side Airbags/Curtains Delete Option (valid with Fleet FIN Code)-557 (XL).

## Optional Traction Control

Reduces engine power through fuel cutoff or ignition spark control. Uses engine torque to manage wheel spin, a more precise method than brake-controlled traction systems. Computes wheel spin from the differential and reduces torque to match the best traction to the wheels for the terrain.

## Stationary Elevated Idle Control (SEIC)

SEIC acts as the "throttle kicker" when increased engine speed is needed. SEIC automatically locks the torque converter. Engine speed at idle is increased to:

- 1,200 RPM (6.8L Triton® gasoline engine)
- 900 to 3,000 RPM (6.7L Power Stroke® diesel engine)



ITEM	F-550 SUPER DUTY CHASSIS CAB
<b>CAB CONFIGURATION</b>	Regular Cab
<b>WHEELBASE (in.)</b>	141, 165, 189, 201
<b>MAX. GVW RATINGS (lbs.)</b>	19,500 (DRW)
<b>AXLE, FRONT (lbs.)</b>	7,000 Dana Super 60
<b>AXLE, REAR (lbs.)</b>	13,660 w/ 17,500 and 18,000 GVWR 15,000 w/ 19,500 GVWR
<b>AXLE RATIO</b>	Gas: 4.88 (Std.), 4.88 LS (Opt.); Diesel: 4.10 (Std.), 4.10 LS (Opt.)
<b>BRAKES, SERVICE</b>	Power, Self-Adjusting Hydro-Boost Assist
<b>BRAKE, PARKING</b>	Four Wheel Disc with Four Wheel Anti-lock
<b>ELECTRICAL - ALTERNATOR</b>	Rear Axle Mounted, 9.5" Drum-in-Hat Type, Foot Operated 157-Amp Heavy Duty (Std. Gas) 200-Amp Extra Heavy Duty (Std. Diesel) Dual 357-Amp (Opt. Diesel)
<b>- BATTERY</b>	12-Volt, 750-CCA/78-Amp Hr (Std. Gas) Two 12-Volt 750-CCA (1,500-CCA Total) 78-Amp Hr (Std. Diesel)
<b>ENGINE/HP/TORQUE</b>	6.8L Triton® 3V SEFI V10 (Std.) 362 HP @ 4,750 RPM/457 lb.-ft. Torque @ 3,250 RPM 6.7L Power Stroke® V8 Turbo Diesel (Opt.) 300 HP @ 2,800 RPM/660 lb.-ft. Torque @ 1,600 RPM
<b>FRAME</b>	Single Channel, 36,000 PSI, Ladder Type
<b>FUEL TANK</b>	10.1 or 17.2 cubic inches SM, Based on Wheelbase and Payload Package 40 Gallon (Std.); Dual 40 Gallon Aft-of Axle and 28 Gallon Mid-ship (Opt. with 6.7L Diesel)
<b>SHOCK ABSORBERS</b>	1.38" Dia. HD Gas-type, Front and Rear
<b>SPRINGS, FRONT COIL TYPE (lbs.)</b>	4,800 to 7,000 (Computer Assigned)
<b>SPRINGS, REAR (lbs.)</b>	13,660 to 15,000 Multi-Leaf, Single Stage Main Plus Auxiliary
<b>STABILIZER BAR, FRONT (in.)</b>	1.26
<b>STABILIZER BAR, REAR (in.)</b>	1.06
<b>STEERING</b>	Power (Includes Steering Damper)
<b>TIRES</b>	(6) 225/70R19.5G BSW All Position (Std. 4x2) (Opt. 4x4) BSW A/S (Std. 4x4) BSW Max. Traction (Opt. 4x4)
<b>WHEELS</b>	(6) 19.5" x 6" RW Argent Painted Steel (Std. w/XL, XLT) (4) Forged Polished Aluminum w/Bright Hub Covers/Center Ornaments (Opt.)
<b>TRANSMISSION</b>	TorqShift® 5-Spd. Overdrive w/Tow Haul Mode; In-Tank Oil Cooler (Std. w/6.8L V10) TorqShift® 6-Speed SelectShift™ Overdrive w/Tow/Haul Mode & Auxiliary Transmission Oil Cooler (Std. w/6.7L V8 Diesel)

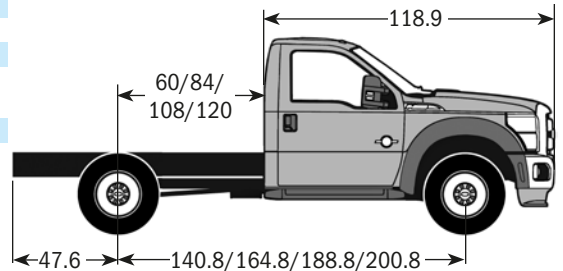

REGULAR CAB

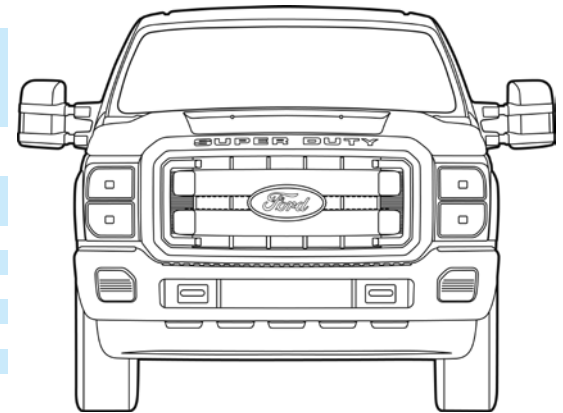

**M** Metric conversion - To obtain information in kilograms, multiply the pounds by .45; to obtain information in kilometers, multiply the miles by 1.6; to obtain information in centimeters, multiply the inches by 2.54.

# F-650 Super Duty Chassis Cab for 2012

## The Right Chassis

F-650 Super Duty Straight Frame offers GVWRs up to 29,000 lbs.

## New For 2012

- The F-650 is now available with the tough and reliable 6.8L Triton® V10 3-valve gasoline engine rated at 362 HP @ 4,750 RPM and 457 lb.-ft. torque @ 3,250 RPM.
- The durable TorqShift® 6-speed double overdrive transmission is mated to the 6.8L engine. The 0.67 overdrive contributes to reduced engine noise and improved fuel efficiency when cruising.

## 281" Wheelbase

The 281" wheelbase Regular Cab is designed for shuttle bus and RV applications, A midship fuel tank is available as well as exhaust to the rear\*.

## Cummins® 6.7L Power

The 6.7L Cummins ISB 200 HP diesel engine is standard on all F-650 models. Ten different horsepower/torque ratings are available, up to 360 HP/800 lb.-ft. torque.

- CARB emissions options available where applicable. Shuttle bus applications qualify as CARB Exempt (Code 633).

## Allison® Automatic Transmission\*

All F-650 chassis cabs can be equipped with an Allison automatic transmission. Allison PTS (Pupil Transportation/Shuttle) Series transmissions provide easy operation, reliable performance and economical maintenance for shuttle bus fleets.

## QuadraLinc™ Hydraulic Brake System

The system provides full power brakes with automatic adjustment and 4-channel ABS. It also includes built-in on-board data acquisition/driver supervision system. Air brakes are also available on the diesel powered chassis.

## Tapered-Leaf Front Suspension

The F-650 front suspension offers excellent balance of ride and handling as well as the ability to handle the most demanding applications. An 8,500 lb. Meritor front axle rating is standard, with a 10,000 lb. front axle rating optional. Both including double-acting shock absorbers. Also available are Dana front axles rated at 8,500 and 10,000 lbs.

## Rear Axle and Suspension

Dana and Meritor rear axles are offered at 17,500 and 19,000 lbs. capacity. All rear axles are available in the recommended Quiet Gears version. F-650 has three multi-leaf and two air suspensions\* available. Air suspensions are available with or without air brakes\*.

## Automatic Traction Control (ATC)

ATC is integrated into the F-650 anti-lock braking system and is available on vehicles equipped with air and hydraulic brakes. When wheel sensors detect wheel slip, the ABS Controller reduces engine power and/or selectively applies rear brakes to transfer power from the slipping wheel to the opposite wheel.

## Comfort and Convenience

- XL and XLT trim levels offer comfort for driver and passengers.
- Power windows with one-touch-down feature on driver's side delivers an unexpected level of convenience.
- A low side window belt line helps improve road visibility on the vehicle's sides.
- Available overhead gauge cluster with oil temperature and hour meter\*.

## F-650 is the Ideal Chassis for Medium Duty Shuttle Bus Applications

A 'work ready' suggested specification list has been developed for shuttle bus builders. Many other options and specifications are also available (please see back cover).

\* Diesel only.

ITEM	F-650 SUPER DUTY DIESEL CHASSIS CAB	Also Available With Gas Engine. See Your Dealer For Specifications.
<b>CAB CONFIGURATION</b>	Regular Cab	
<b>WHEELBASE (in.)</b>	146, 158, 176, 182, 194, 200, 212, 218 224, 231, 242, 260, 281	
<b>MAX. GVW RATINGS (lbs.)</b>	29,000	
<b>AXLE, FRONT (lbs.)</b>	8,500 (Std.); 10,000 (Opt.)	
<b>AXLE, REAR (lbs.)</b>	17,500 (Std.); 19,000 (Opt.)	
<b>AXLE RATIO</b>	2.69-7.17 w/1-speed axle; 3.90/5.32 to 7.17/9.77 w/2-speed axles	
<b>BRAKES, SERVICE (Standard)</b>	Power, Hydraulic, Automatic Adjusting Full Power	
<b>BRAKE, PARKING (Standard)</b>	Four-Wheel Disc with Four-Wheel Anti-lock	
<b>BRAKES, SERVICE (Optional)</b>	12" x 3" Rear Axle Mounted, Bosch DSSA Type Power, Full Air, Automatic Adjusting	
<b>BRAKE, PARKING (Optional)</b>	Four-Wheel Disc with Four-Wheel Anti-lock System	
<b>ELECTRICAL - ALTERNATOR</b>	Spring Parking Brake Chambers Mounted Front of Rear Axle 185-Amp - 2,495 Watt (Std.) 220-Amp - 2,970 Watt (Opt.) 320-Amp - 4,320 Watt (Opt.)	
<b>- BATTERY</b>	Two 625-CCA (1,250-CCA Total) (Std.) Three 625-CCA (1,875-CCA Total) (Opt.) Two 900-CCA (1,800-CCA Total) (Opt.) Three 900-CCA (2,700-CCA Total) (Opt.) Two 625-CCA (1250-CCA Total) Temporary Mount (Opt.) Two 900-CCA (1800-CCA Total) Temporary Mount (Opt.)	
<b>ENGINE/HP/TORQUE</b>	Cummins (Std.) 200 HP @ 2,300 RPM (Std.) to 360 HP @2,600 (Opt.)	
<b>FRAME</b>	Single Channel, Tapered, 50,000 PSI (Std.)	
<b>FUEL TANK</b>	45 Gal. (Std.) up to 145 Gal. Capacity Dual Tanks (Opt.)	
<b>SHOCK ABSORBERS</b>	Double Acting Front (Std.); Rear (Opt.) (Incl. w/Air Rear Suspension);	
<b>SPRINGS, FRONT TYPE (lbs.)</b>	8,500 (Std.), 10,000 (Opt.) Parabolic Taper-leaf	
<b>SPRINGS, REAR (lbs.)</b>	18,500 (Std.), 15,500 (Opt.), 20,000 (Opt.) Vari-Rate Multi-leaf Incl. 4500 Rubber Aux. 18,500 or 20,000 (Opt.) Air Suspension	
<b>SPRINGS, FRONT AUXILIARY</b>	Rubber	
<b>STEERING</b>	Integral Power Steering	
<b>TIRES</b>	11R 22.5H 16PR (Std.); 225/70R19.5 12PR (Opt.)	
<b>WHEELS</b>	10-Hole 22.5"x7.5" Steel Disc (Std.); 8-Hole 19.5"x6.75" Steel Disc (Opt.)	
<b>TRANSMISSION</b>	6- or 7-Speed Manual; 5- or 6-Speed Allison Automatic	

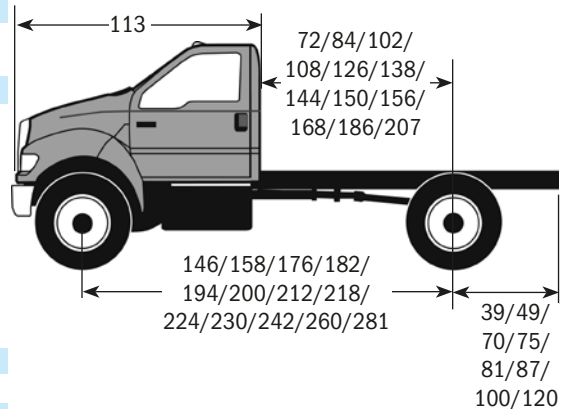

**M** Metric conversion - To obtain information in kilograms, multiply the pounds by .45; to obtain information in kilometers, multiply the miles by 1.6; to obtain information in centimeters, multiply the inches by 2.54.

## 2012 F-650 Super Duty Recommended Shuttle Bus Builder Specs

The options list below reflect the equipment most often selected by Shuttle Bus Body Builders and Operators for buses built on a Ford Medium Duty Chassis. Additional options are available.

- F-650 Regular Cab XLT · 25,999 lbs. GVWR
- 260" Wheelbase · 186" CA
- Cummins 6.7L ISB, Allison 2200 (PTS Series) and 5.29:1 Axle Ratio
  - Geared Speed: 77 MPH
  - Cruise Speed: 60 MPH @ 1,791 RPM
  - Startability: 19.6% in 1st Gear

Code	Item	Description
F6F	F-650	Regular Cab-Straight Frame
---	260 (inches)	Wheelbase
YZ	Paint	Oxford White
20Y	GVWR	Special - Limited to 25,999 Lbs.
534	Frame	29,000 Lbs. Max. Frame Rating (Std.)
43H	Front Axle	Meritor MFS-10-122A - 10,000 Lbs. Rating
61C	Front Springs	10,000 Lbs. Rating
61Y	Front Springs	Auxiliary
---	Wheel Seals	Front - Stemco
477	Rear Axle	MS-19-145 -19,000 Lbs. Rating - Includes Quiet Gearing
X5B	Axle Ratio	5.29:1
68E	Rear Suspension	Air Suspension -18,500 Lbs. Rating
68Z	Control	Rear Suspension Dump Valve
---	Wheel Seals	Rear - Stemco
67J	Brakes	Hydraulic - Quadratic; Includes Bosch DSSA Parking Brake
62B	Compressor	Cummins 18.7 CFM
62R	Drain Valve	Automatic
99B	Engine	Cummins 6.7L Diesel - 220 HP
41G	Block Heater	Phillips 120-Volt/750-Watt
17D	Alternator	320-Amp Leece-Neville
425	Emissions	50 State
633	Emissions	CARB Exempt (Bus)
44E	Transmission	Allison 2200 6-Speed PTS
91A	Exhaust	Right Side Horizontal - Exit Front of Rear Wheels
65N	Fuel Tank	65 Gallon Mounted Left Side
86H	DEF Tank	10 Gallon Diesel Emission Fluid Tank
682A	PEP	XLT Preferred Equipment Package
882	Seat	Driver - 40% Width - Air Suspension - Steel Gray Cloth
85R	Seat	Passenger - 40% Width - Steel Gray Cloth Or
85X	Seat Delete	Delete passenger seat when right hand door is to be removed
63G	Battery	Two 12-Volt, 900-CCA Temporary Mounted
16V	Voltmeter	Mounted in Overhead Pod
17H	Hourmeter	Mounted in Overhead Pod
962	DRL	Daytime Running Lights
55X	Tail Lights	Delete
54F	Mirror	Sail Mounted - Power Telescoping, Folding, Heated Glass
647	Wheels-Front	22.5X7.5 10-Hole Steel
667	Wheel-Rear	22.5X7.5 10-Hole Steel
TFA	Front Tires	Michelin 235/80R22.5G XZE
RFA	Rear Tires	Michelin 235/80R22.5G XZE
H7X	VSO Code	Relocated DEF Tank
31P	PDI	Manning

### Other Available Options

43B	Front Axle	Dana I-100SG - 10,000 Lbs. Rating
47L	Rear Axle	Dana S17-140 -19,000 Lbs. GenTech
60A	Lube	Front Axle - Synthetic
608	Lube	Rear Axle - Synthetic
62D	Air Dryer	Bendix AD/IP Heated
55M	Start Aid	Battery Jump Start Stud

Note: If using biodiesel fuel, Ford recommends biodiesel fuel that is no higher than 5 percent (B5) on F-650, 20 percent (B20) on F-Series Super Duty through F-550. Follow the Special Operating Conditions Maintenance Schedule if using biodiesel.

All incomplete vehicle packages listed in this document require further manufacture and certification by a final stage manufacturer. In addition, Ford urges shuttle (transit) bus manufacturers to follow the recommendations of the Ford Incomplete Vehicle Manual and the Ford Truck Body Builders Layout Book (and pertinent supplements).

## Ford QVM Program for Shuttle (Transit) Bus Builders

Ford is not only interested in providing safe, high-quality chassis, we also recognize the need for final-stage manufacturers to meet the special vehicle requirements of their customers. To promote reliability and quality of modified Ford products, we publish the Qualified Vehicle Modifier Program guidelines for final stage manufacturers. We also provide technical assistance and assess builder's processes and quality operating systems.

We are proud to work with the best Vehicle Modifiers in the business to complete your personalized fleet requirements. Each one offers a unique lineup of bodies to match your Ford chassis.

- Ameritrans (TMC Group)
  - Champion Bus, Inc.\*
  - Coach & Equipment Mfg. Corp.\*
  - Collins Bus Corp. (World Trans)\*
  - Diamond Coach Corp.\*
  - EIDorado National, Inc.\*
  - Elkhart Coach\*
  - Executive Coach
  - Federal Coach
  - Glaval Bus\*
  - Goshen Coach\*
  - Krystal Coach\*
  - Prime Time Specialty Vehicles, Inc.
  - Starcraft Bus\*
  - StarTrans Bus (Supreme)\*
  - Tiffany Coachworks
  - Turtle Top\*
- \* Ford Pool Account

## SUPPORT

### Roadside Assistance

This 24-hour, seven-days-a-week service is a standard feature on all Ford Commercial Chassis. By dialing 1-800-241-3673, Ford Commercial Truck customers also have access to:

- Flat tire change (requires useable spare tire)
- Fuel delivery, if out of fuel
- Warranty/non-warranty/collision towing
- Battery jump-start
- Lockout assistance
- Winch out

Note: F-650/F-750 are eligible for jump start, lockout and towing services.

- Coverage Period:
  - E-Series and F-Series Super Duty (F-250-550): 5-years/60,000 miles, whichever occurs first.
  - F-650/F-750: 2-years/unlimited miles

### In-Dealership Service Support

- Over 3,500 Ford dealerships in the U.S. and Canada are available to provide service support.
- In-dealership certified service technicians backed by computerized diagnostics and national hotline support
- Dealers provide verification of available owner notification and recall information affecting Ford Commercial Chassis.

### Warranty Information

- 2012 model Ford Commercial Chassis (thru F-550) have a Bumper-to-Bumper limited warranty of 3-years or 36,000 miles, and a Powertrain limited warranty of 5-years or 60,000 miles, whichever occurs first.
- 2012 model F-650 has a limited warranty for 2-years and unlimited miles that provides Basic, diesel and Ford drivetrain (axles, driveshaft and transmission) coverage. See your dealer for F-650 gas engine/transmission warranty details.
- The Power Stroke® diesel engine has a limited warranty of 5-years or 100,000 miles, whichever occurs first.
- Parts of the vehicle manufactured and covered by Ford Motor Company are listed in the Warranty Information Booklet that comes with the vehicle. It states the vehicle owner's rights and responsibilities, and should be read carefully.
- Non-Ford diesel engines and transmissions are warranted by the manufacturer. Please refer to the manufacturer's limited warranty statement.
- Corrosion Protection - Sheet metal manufactured and installed by Ford is protected against rust through (perforation) for 5-years/unlimited miles for commercial chassis (thru F-550) and 3-years/unlimited miles for F-650.
- See dealer for details.



Ford Division  
Commercial Truck Sales & Marketing

Information for this publication was correct at the time at which the material was being prepared for printing. Specifications and availability shown are subject to change without notice and Ford Motor Company assumes no liability for such changes.