

TASCA

BUSINESS PREFERRED



401-681-1300



TASCA.COM



TASCA BUSINESS PREFERRED SALES & FINANCE



TASCA'S TEAM OF COMMERCIAL SALES
& LENDING SPECIALISTS IS DEDICATED
TO SERVING THE NEEDS OF TASCA'S
BUSINESS PREFERRED CUSTOMERS

Ford Credit's Commercial Lending Services is dedicated to the commercial vehicle business and is a valuable part of

TASCA BUSINESS PREFERRED.

Our knowledge of the finance & commercial leasing market makes us uniquely qualified to meet your needs. We are ready to work with you and provide products and services to satisfy all your needs.

CUSTOMER BENEFITS

Dedicated Commercial Sales Team with over 25 years of experience. Specializing in light, medium & heavy duty commercial vehicles.

Competitive Rates - regardless of how many trucks your fleet operates.

Lines of credit available on all products.

Flexible finance plans that suit your needs - regardless of transaction size.

We offer a full array of products specifically designed for the commercial end-users including:

CommercialLease

A lease with flexible terms and billing (single bill) and all the advantages of a lease.

CommercialLease Plus

A lease with all the benefits of CommercialLease, PLUS an array of Fleet Management Services.

Finance Plans

Conventional Lending with flexible terms.

Municipal Lease

Financing product structured to meet the needs of state, local and municipal governments

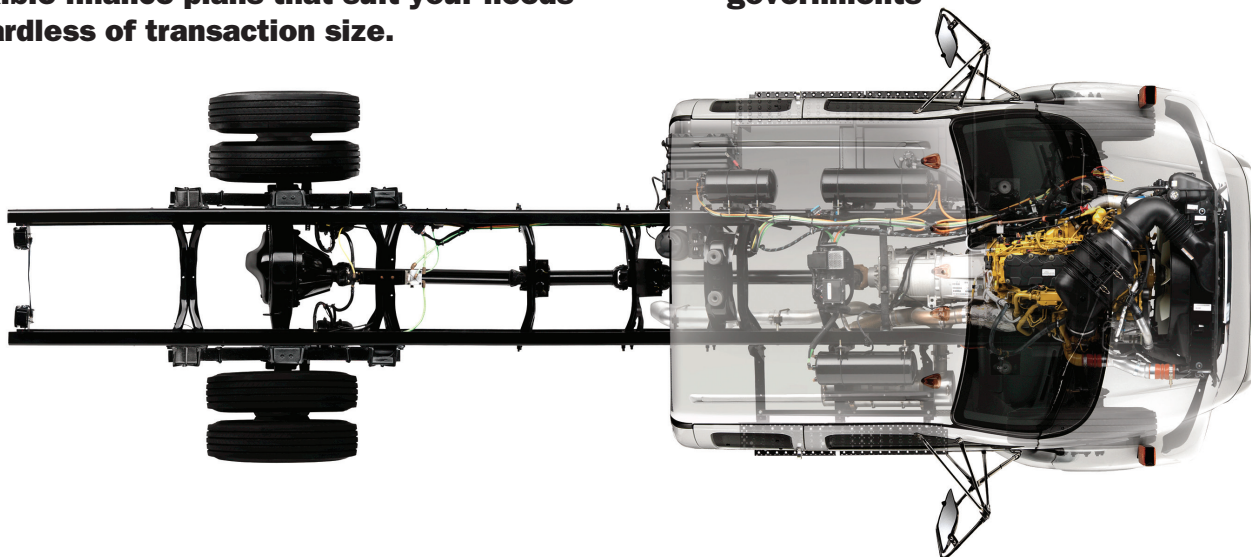

TASCA BUSINESS PREFERRED



TASCA BUSINESS PREFERRED PARTS & SERVICE COLLISION CENTER



TASCA IS YOUR COMMERCIAL FLEET SPECIALIST.

HERE'S WHAT WE CAN DO FOR YOU...

SERVING ALL MAKES & MODELS

- The most factory trained technicians in New England.
- Maintenance & repair on all makes & models
- The most certified Ford Diesel Technicians in New England.
- Cummings Certified.

SERVICE UNTIL MIDNIGHT & SAT.

- Two locations: Cranston, RI & Seekonk, MA.
- We're always here to fix your truck and keep it working for you.

TASCA COMMITMENT

- No appointment necessary.
- No charge initial diagnostic.
- 24 hour guaranteed diagnosis.
- The most commercial service capacity in New England.

STATE-OF-THE ART COLLISION CENTER ON SITE

- When making an appointment let us know that you're a TASCA BUSINESS PREFERRED CUSTOMER and we will get you in within 24 hours to repair your vehicle.

TASCA COMMITMENT

- 90-day same as cash available.
- Credit approval required.
- Ask about our Quality Fleet Charge & Management Account.
- Ask about other options you may qualify for.

PICK-UP & DELIVERY SERVICE

- Available upon request.
- Subject to restrictions.

PREFERRED OVERNIGHT PARTS DELIVERY

- Largest parts inventory on the East Coast.
- 30 delivery trucks covering all of New England.

DISCOUNTED LABOR & PARTS PRICING

- Receive valuable FLEET savings.
- No need to wait for credits at the end of the month.

FREE SANDWICH & CAR WASH

- Every time you visit our dealership for service, you will receive a coupon for a free sandwich at our TasCafe located within the dealership, and we will even wash your vehicle. (Available with purchases over \$24.95).

CONTACT US	
SERVICE.....	401-681-1310
PARTS.....	401-681-1360
BODY SHOP.....	401-681-1296
SALES.....	401-681-1300
MOD SHOP.....	401-681-1122

TASCA BUSINESS PREFERRED



TASCA BUSINESS PREFERRED



ENROLLMENT APPLICATION

COMPANY INFORMATION

Company Information: _____

Address: _____

Contact: _____ **Title:** _____

Phone: _____ **Fax:** _____

Email Address: _____

Website: _____

VEHICLE INFORMATION

Number of trucks in Fleet: _____

Year: _____

Model: _____

Mileage: _____

WORK AUTHORIZATION

Name: _____

Phone: _____

Email Address: _____

PURCHASE ORDER REQUIRED (CIRCLE ONE)

Yes No

PAYMENT METHOD

Visa: _____ **MasterCard:** _____

AmEx: _____ **Discovery:** _____

Quality Fleet Care Program: _____

Commercial Fleet Lease Program: _____

Other: _____

TASCA BUSINESS PREFERRED



TASCA IS THE TRUCK AUTHORITY

- **NO APPOINTMENT NECESSARY**
- **GUARANTEED DIAGNOSIS WITHIN 24 HOURS**
- **NO CHARGE INITIAL DIAGNOSTIC**
- **PICK-UP & DELIVERY SERVICE AVAILABLE***
- **SERVICING ALL MAKES & MODELS**
- **SERVICE UNTIL MIDNIGHT & SATURDAYS**
- **DISCOUNTED LABOR & PARTS PRICING**
- **PREFERRED OVERNIGHT PARTS DELIVERY**
- **FLEXIBLE PAYMENT OPTIONS**
- **FREE SANDWICH & CAR WASH**

***SEE FACT SHEET FOR DETAILS**



401-681-1300 • TASCA.COM